



SERVICE SHOP NOTES

LIMA[®] MAC SELF VOLTAGE REGULATED GENERATORS

Troubleshooting Tips

Symptom: Engine bogs down or stalls even at no load.

Problem: Main stator has one or more taps wound or connected incorrectly. (99% probability). This problem is only seen with generators having taps on their main stator coils. It is not seen with the newer “No Tap MAC” designs.

Solution: Use ohmmeter to check the resistance between the leads.

12 Lead Generator Procedure, Reference Connection Diagram 14002-31:

Check resistance from T13-T4. It should be some small number. Then check from T4-T16. It should be a little bit smaller or about the same if not easily detectable. Then check T13-T16. This should be almost zero. If T16-T4 is almost zero, swap the lead numbers from T13 and T16. Repeat the procedure for the other six sets of coils and leads. If the reading from T4-T16 is nearly equal to T4-T13, the internal connection between coil one and four is wrong. It must be broken and corrected. Repeat the procedure for the other six sets of coils and leads.

10 Lead Generator Procedure, Reference Connection Diagram 14002-50:

Check resistance from T10-T4. It should be some small number. Then check from T4-T16. It should be a little bit smaller or about the same if not easily detectable then check T10-T16. This should be almost zero. If T16-T4 is almost zero, swap the lead numbers from T10 and T16. Repeat the procedure for the other six sets of coils and leads. If the reading from T4-T16 is nearly equal to T4-T10, the internal connection between coil one and four is wrong. It must be broken and corrected. Repeat the procedure for the other six sets of coils and leads.

Comment: It is not necessary for the conduct of this procedure to have a meter that is accurate for very small resistances. The actual value of specific resistances is not needed here. What is required, is to measure is the relative difference in values.

Symptom: No voltage

Problem: Flash the field. See restoring residual magnetism procedures on page 4. Assuming the field was flashed and there are no defective diodes, the most common problem after rewinding is the wrong phase sequence on one or both

stators. In rare cases, the diodes are all in working order but there can be a poor connection on the rectifier assembly. Check all connections for corrosion.

Solution: Swap lead numbers from two phases on one stator only. The main and exciter stator must have the opposite phase sequence to generate voltage. See the phase sequence reversal procedure detailed on pages 5 and 6 below.

Symptom: Good voltage but one or more tapped coils gets hot under load.

Problem: The most common problem is swapping the main lead with the tap lead next to it. They both come out of the same slot and are easily mixed up. The tapped turn(s) are designed to carry no load shunt current only. If the leads are swapped, the tap carries shunt current and load current. This causes the tap to overheat.

Example: See Example under "Engine bogs down".

Solution: If the resistance from T4-T13 is less than T4-T16, then swap T13 & T16. Check and repeat for all other groups.

Symptom: Good voltage but one or more tapped coils gets hot without any load.

Problem: Poor connection to all strands used for tapped coil.

Solution: See "Connection" directions.

Symptom: Good voltage no load but very low voltage under full load.

Problem: Assuming there is no exciter damage or defect, the most likely cause is incorrect main stator coil insertion.

Solution: See Coil Insertion directions .

Rewinding Tips For "Tapped MAC" Generators

Coil Winding

The taps should be the specified number of turns (usually 1 or 2) away from the start or end of the coil group. 250 frames have taps at the end of the coils and all others have taps at the beginning of the coils. Only the first or last coil of the coil group should be tapped. Taps are typically made with a small twist in the wire while winding the coils.

Coil Insertion

Using either 14002-31, or 14002-50 as a reference, the coil insertion can be seen using the "Coil Connect" circle. Tapped coils have a "C" to denote the tap. Standard coils have "A" & "B" ends only. The "A" side of the coils lie in the bottom of the slot toward the "outside" of the core. The "B" side of the coils lie on top of another coil in the slot toward

the "inside" of the core. One side of the tapped coil occupies the same slot as the "B" end and the other side is four slots away from the "A" end. The tap can be made anywhere between these two points. Diagram 14002-133 and -134, used for 250 MAC only, have the taps on the opposite side. Using -31 instead of -133 on a 250 MAC may result in low voltage under load.

Viewing the "Coil Connect" circle as shown, the coils are inserted in a counter-clockwise (CCW) direction. The "A" side is inserted first in a CCW direction. Coil end "A" is in the last slot to be inserted. The "B" side is then inserted. After insertion, coil ends "A" & "B" must be at the outer edges of the coil group. If they are inserted to the inside of the coil group, the unit may have low voltage under load. See Diagram 1. Inserting the coils in a clockwise direction is acceptable if done consistently. It may result in a reversed phase sequence though.

LIMA® MAC MAIN STATOR COIL INSERTION DIAGRAM

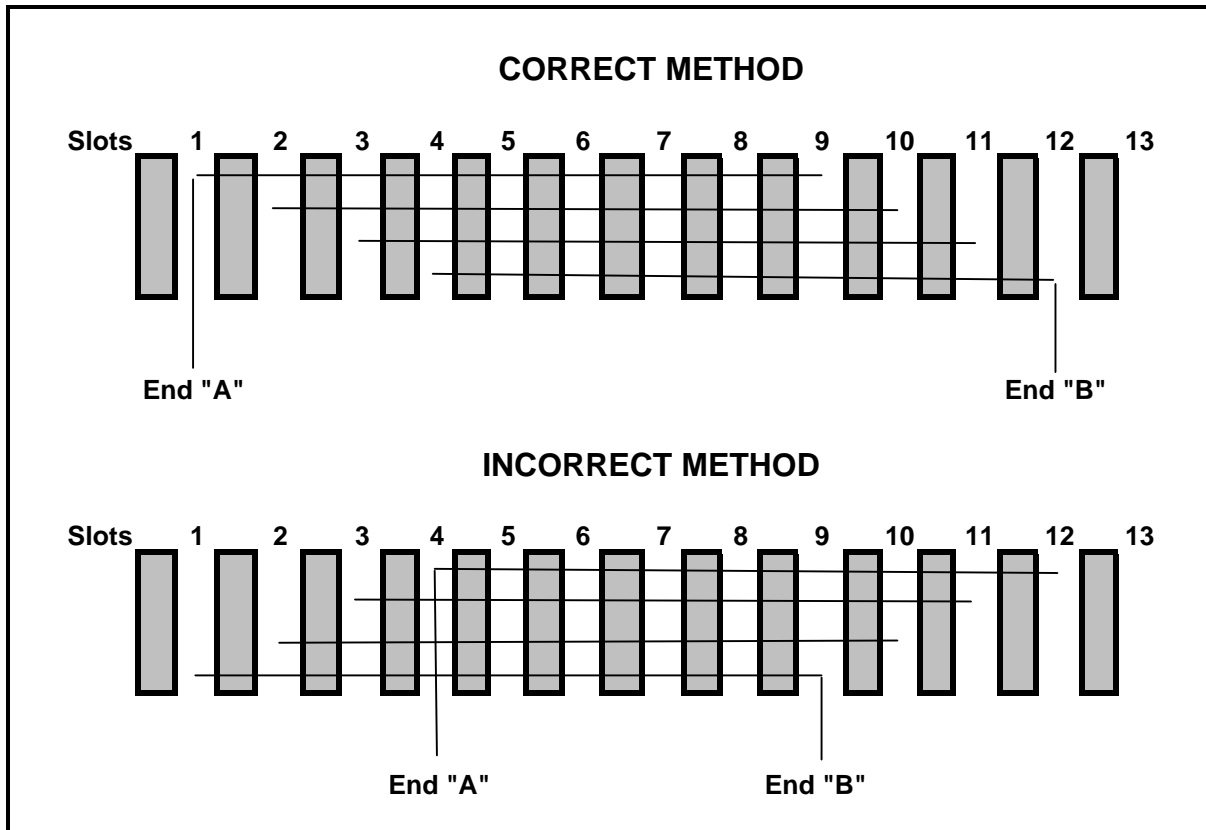

DIAGRAM 1

Connections

Coils are to be connected as shown in the "Connect Table". All coil ends and leads on the same line are connected together. Refer to the "Coil Connect" circle for coil

numbers. The "Lead Tag" circle is a physical representation of the lead locations after connecting but before lacing. It is used to speed connect time but the table contains all necessary information. Electrically they will be as shown in the schematic diagram. The tap lead must be electrically connected to all strands in the turn. If two strands of magnet wire are used per turn, the lead must be connected to both of them.

Restoring Residual Magnetism

The current necessary to magnetize the alternator field during operation is obtained from the exciter. Initially, upon starting the unit, voltage is induced into the main stator (armature) by the flux across the air gap supplied by the permanent magnets embedded in the poles of the main rotor. Current then flows through interconnecting leads to the shunt portion of the exciter stator which induces current in the exciter rotor. This current is then rectified to DC excitation current by the rotating rectifier, and fed to the main field windings via the main rotor leads further strengthening the main field until rated voltage is reached.

The residual magnetism contained in the field poles of the main rotor may be lost or severely weakened when the unit is disassembled for rewinding or other service operation. Should the generator fail to build up voltage after being reassembled, a momentary short circuit of any two generator output leads while the unit is running at rated speed should be sufficient to correct this condition. This action is termed "Flashing the Field".

If the voltage does not build up with the above procedure, an alternate method may be used. Apply either an alternating or direct current voltage of from 24 to 30 volts to any two generator output leads. (Again - this procedure is conducted with the generator running at rated speed) Do not make a firm connection, but rather touch the leads together until the generator voltage begins to rise and then remove. It is suggested that a 30 ampere fuse be inserted in the supply voltage circuit to prevent any damage in case the build-up power supply voltage is not removed quickly enough.

Start the generator and observe voltage build-up. Re-flash field if generator voltage does not build up. Verify that generator speed is at, or slightly above rated nameplate speed.

Ball Testing of Stator Windings

A ball test is simply another method of testing a stator winding to check for proper connections. The equipment consists of a large steel ball usually 1 to 2 inches in diameter. The diameter should be slightly larger than the distance between two adjacent stator slots. Sometimes, an inner or outer race of a ball bearing is used. The winding is usually connected in the high voltage wye connection, and a reduced voltage (about $\frac{1}{2}$ voltage) is applied to the output leads. The ball or race is then placed on the inside of the stator core. If the completed winding has been done properly, the ball will spin

around the inside of the core at an even or uniform rate. If the winding is improperly connected, the movement of the ball will be erratic, or perhaps no movement will occur.

Reversing the Phase Sequence of a Rewound Stator.

There have been many instances where a repair facility will rewind either a main stator or an exciter stator on a Lima[®]MAC generator, and then not be able to generate a voltage at the terminals during test running. In almost every case of this nature, the problem is either in a loss of residual magnetism, or with the phase sequence of the rewind stator. **The phase sequence of the exciter stator must be opposite to that of the main stator, or the unit will not build up voltage.** To correct an improper phase sequence problem, you will have to reverse the phase sequence of the rewind stator. To reverse the phase sequence of a stator winding, all lead tags of one phase of the stator will be switched with the leads the next phase, and then these renumbered leads will be connected to matching numbered leads of the original (non-rewound) stator. If both stators have been re-wound, reverse tag only one stator.

Suggestion: After a stator rewind, run a ball test on both stators once they are installed in the frame and inter-connected. **The ball in the main stator must rotate in the opposite direction to that of the exciter stator.** If rotation is the same for both stators, reverse tag using the procedures below, and re-connect before proceeding with installing the rotor assembly in generator.

A. Reverse tagging of the main stator of a 12 lead MAC generator. Break apart the connections of leads T13, T16, T19, T22; and T14, T17, T20, T23. Working only on the leads of the main stator: Physically re-tag lead T13 - T14, and T14 - T13; T16 - T17, and T17 - T16; T19 - T20, and T20 - T19; T22 - T23, and T23 - T22. Leads T4, T5, T10, and T11 are out put leads. Re-tag T4 - T5, and T5 - T4; T10 - T11, and T11 -T10. You have now reversed the phase sequence of the exciter stator. Re-interconnect these leads to the main stator leads, re-install the splice insulation, bundle the entire group of interconnecting leads as before. Now connect the generator output leads for the proper connection, and retest.

B. Reverse tagging of the main stator of a 10 lead MAC generator. Break apart the connections of leads T10, T16, T13, T19; and T11, T17, T14, T20. Working only on the leads of the main stator: Physically re-tag lead T10 - T11, and T11 - T10: T16 -T17 and T17 - T16: T13 - T14 and T14 -T13: T19 - T20 and T20 -T19. Since load leads T4 and T5 are output leads, simply swap their tags to make T4 become T5, and T5 to become T4. You have now reversed the phase sequence of the main stator. Re-interconnect these leads to the exciter stator leads, re-install the splice insulation, bundle the entire group of interconnecting leads as before. Now connect the generator output leads for the proper connection, and retest. It may well be that you will have to flash the field to achieve voltage build-up after this procedure.

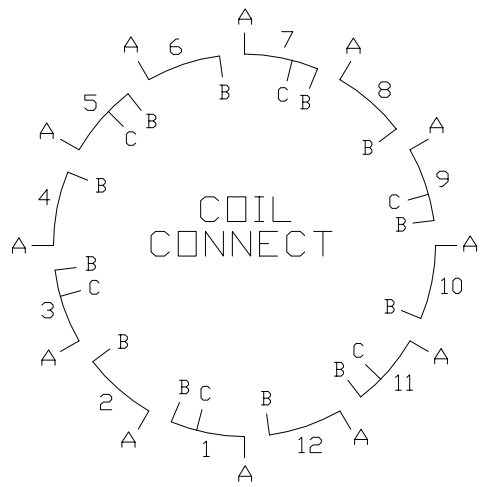
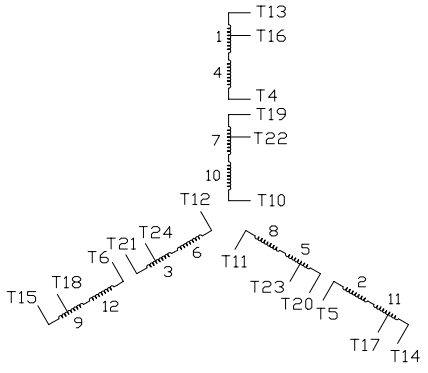

LEAD BREAKOUT

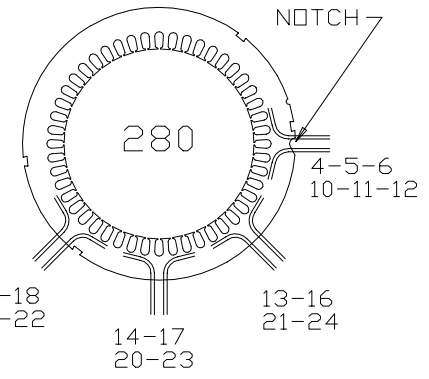

SEE DRW. B-779559-0A FOR LEAD BREAKOUT OF MAIN STATORS NOT SHOWN

CONNECT TABLE

OUTSIDE (A)	INSIDE (B)	LEAD TAGS
1A	4A	
3A	6A	
5A	8A	
7A	10A	
9A	12A	
11A	2A	
	1B	T13
	11B	T14
	9B	T15
	7B	T19
	5B	T20
	3B	T21
	4B	T4
	2B	T5
	12B	T6
	10B	T10
	8B	T11
	6B	T12
	1C	T16
	11C	T17
	9C	T18
	7C	T22
	5C	T23
	3C	T24

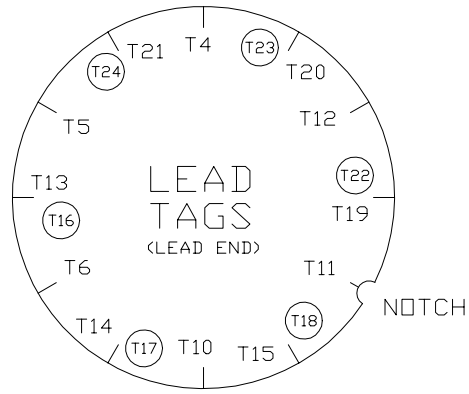

TAPS FOR FULL TURNS ONLY

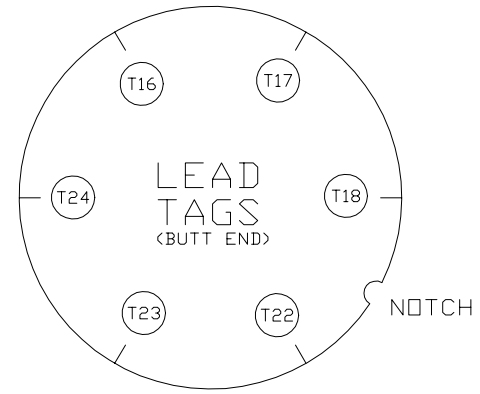

TAPS FOR HALF TURNS ONLY

5	11-08-95	REARRANGED COIL CONNECTIONS CN 7197	KL	✓ SURFACE ROUGHNESS UNLESS NOTED OTHERWISE	UNLESS OTHERWISE SPECIFIED DIMENSIONS ARE IN INCHES TOL. ON XX± XXX±.005 XXXX±.0005 ANGLES±
4	5-22-95	REISSUE FOR NEXT REVISION CN 6915	DA	MATL SPEC	DRAWN DA 5-17-95
3	5-18-95	REDRAWN & CLARIFIED PER CN 6915	DA	FINISH	CHKD BY PR 5-18-95
					APPD BY WBD 5-18-95
REV	DATE	CHANGE	NAME	PART NAME CONNECTION DIAGRAM - MAIN STATOR 3 PH, 4 POLE, 1/2 Y, 12 LEAD, MAC, TAPPED COILS	DRWG NO B-14002-31

SHOP BOOK PURCHASED DISTRIBUTION - ~~W~~ - ~~L~~ - ~~W~~ - LM CADD FILE NO. 14x2x031

Uncontrolled Copy

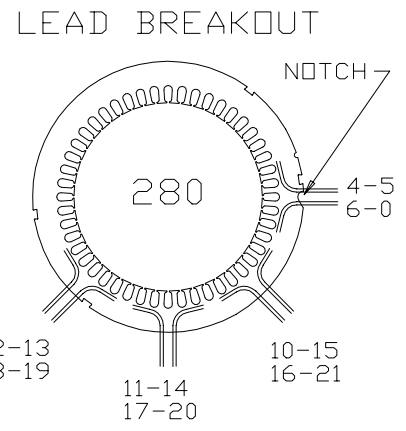
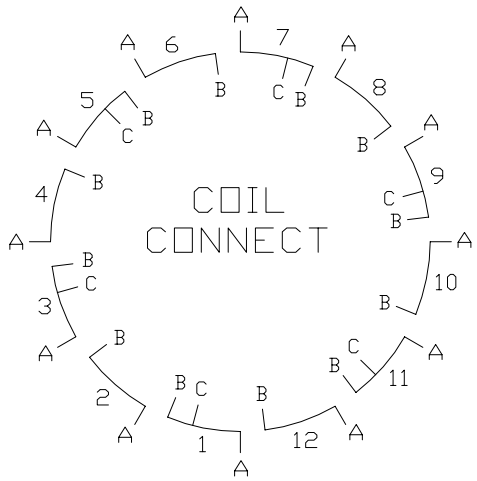
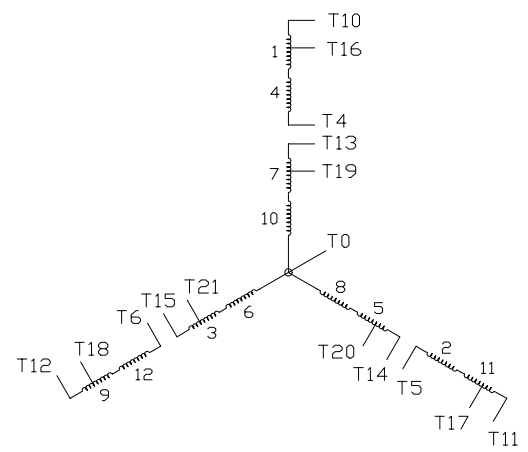

SEE DRW. B-779559-0A FOR LEAD BREAKOUT OF MAIN STATORS NOT SHOWN

CONNECT TABLE

OUTSIDE (A)	INSIDE (B)	LEAD TAGS
1A 4A		
3A 6A		
5A 8A		
7A 10A		
9A 12A		
11A 2A		
	6B 8B 10B	T0
	1B	T10
	11B	T11
	9B	T12
	7B	T13
	5B	T14
	3B	T15
	4B	T4
	2B	T5
	12B	T6
	1C	T16
	11C	T17
	9C	T18
	7C	T19
	5C	T20
	3C	T21

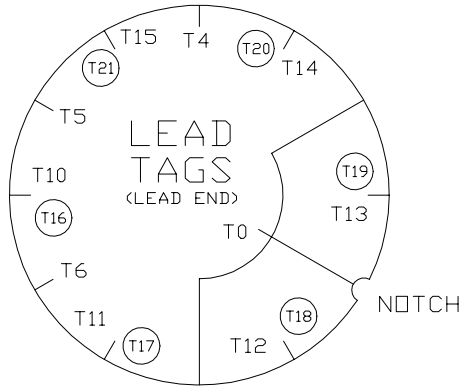

TAPS FOR FULL TURNS ONLY

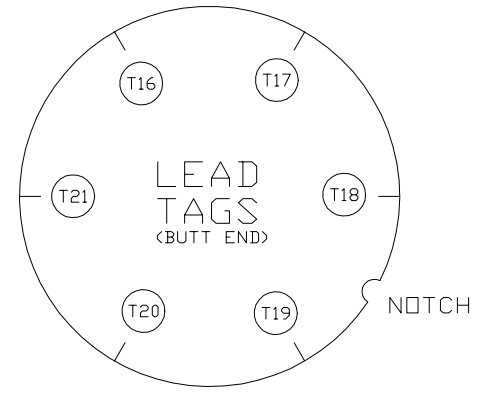

TAPS FOR HALF TURNS ONLY

5	11-08-95	REARRANGED COIL CONNECTIONS CN 7197	KL	<input checked="" type="checkbox"/> SURFACE ROUGHNESS UNLESS NOTED OTHERWISE UNLESS OTHERWISE SPECIFIED DIMENSIONS ARE IN INCHES TOL. ON XX# XXX#±.005 XXXX#±.0005 ANGLES±
4	5-22-95	REISSUE FOR NEXT REVISION CN 6915	DA	MATL SPEC FINISH DRAWN DA CHKD BY PR 5-17-95 5-18-95
3	5-18-95	REDRAWN & CLARIFIED PER CN 6915	DA	PART NAME CONNECTION DIAGRAM - MAIN STATOR 3 PH, 4 POLE, 1/2 Y, 10 LEAD, MAC, TAPPED COILS WAUSAU, WISCONSIN 54401 APPD BY WBD 5-18-95
REV	DATE	CHANGE	NAME	DRWG NO B-14002-50 14x2x050

SHOP BOOK PURCHASED DISTRIBUTION - ~~W~~ - ~~L~~ - ~~W~~ - LM CADD FILE NO. 14x2x050

Uncontrolled Copy